

OMBEA ExpressPod™ EP-02 Small

Technical Specifications

EP02S-LITE

Mount:	Wall Mount
Overall Dimensions:	16.5 x 15.2 x 1.2 cm (HxWxD)
Packaging Dimensions:	19 x 16 x 5.5cm
Weight:	0.375kg
Batteries:	2 x CR2450
Battery Life:	3 year
Communication	2.4 GHz, IEEE 802.15.4
Buttons	5 x Smiley buttons 5 x A-E buttons
Question Sheet Format:	A6 (148mm / 5.8")
Parts Included in Package:	1 x Smiley Lid 1 x Letter Lid 1 x Pod 1 x Stand 1 x Question Holder
Warranty	Lifetime Hardware Warranty
Works With	Works with AirLink 01

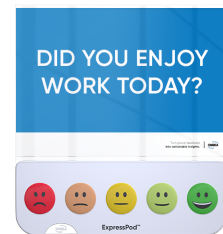

Detailed Drawings (mm)
EP02S-LITE

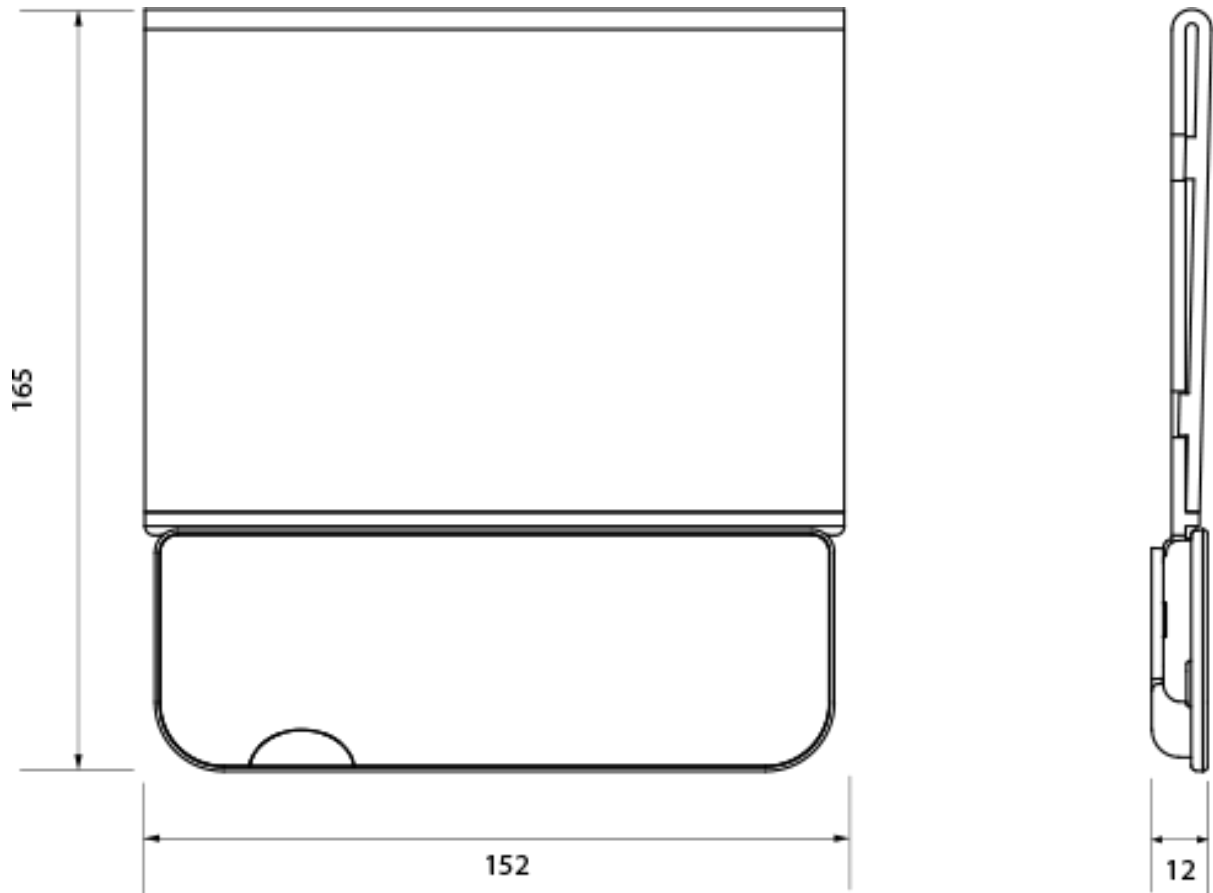

OMBEA AirLink™ 01

Technical Specifications

Overall Dimensions:	2.5 x 11.7 x 11.7 cm (HxWxD)
Packaging Dimensions:	24 x 16 x 4.5cm
Weight:	0.310kg
Power Supply:	External Power Adapter
Communication	2.4 GHz, IEEE 802.15.4
Parts Included in Package:	1 x AirLink 01 1 x Power Adapter
Warranty	Lifetime Hardware Warranty
Works With	Works with EP02 Lite versions



Detailed Drawings (mm)

